

MAGTFTC, MCAGCC SOP FOR
INSPECTION AND TEST OF LIGHTNING PROTECTION AND GROUNDING SYSTEMS FOR
ORDNANCE FACILITIES AND AIRCRAFT LOADING/DOWN LOADING AND FUELING
POINTS

Ref: (a) NAVSEA OP S Vol 1 (NOTAL)
(b) National Fire Protection Code (NFPA) 780 (NOTAL)
(c) Department of the Navy Grounding and Lightning Protection Systems Handbook (NOTAL)
(d) NAVAIR 00-80T-103 (NOTAL)
(e) MIL-HNDB-274(AS) (NOTAL)
(f) NAVAIR 1720AR-11 (NOTAL)
(g) Grounds Test Schematic for Center Magazine Area
(h) Grounds Test Schematic for Marksmanship Training Unit
(i) Grounds Test Schematic for Expeditionary Airfield & Ammunition Issue Point

Encl: (1) MAGTFTC, MCAGCC Inspection and Test of Lightning Protection and Grounding Systems for Ordnance Facilities and Aircraft Loading/Down Loading and Fueling Procedural Guidance

1. Situation. To define responsibilities for the development of individual grounding system test plans, ensure, establish and implement a lightning protection system (LPS) maintenance plan for all explosive areas aboard the Marine Corps Air Ground Combat Center (MCAGCC), per reference (a). Maintenance actions support include but are not limited to: the development of individual grounding system test plans, ensuring explosive areas are available and safe for inspections, performance of periodic visual inspections, performance of periodic electrical tests, archiving test and inspection data, review of test data, prioritizing deficiency repairs, issuing work requests and performing repairs.

2. Cancellation. CCO 11000.8.

3. Mission. This Manual provides procedures and defines responsibilities for:

a. Visual inspection and testing of electrical, lightning and electrostatic grounding systems for all electrical equipment, apparatus, machinery, metallic conduit and all accessories that are a part of the electrical distribution system.

b. Inspecting and conductivity testing of metal masses, structural supports lightning masts, hardware, equipment enclosures etc., and buried ground cable networks (i.e., primary and secondary ground girdles).

4. Execution

a. Commander's Intent and Concept of Operations

(1) Commander's Intent.

(a) The fundamental principal in the protection of life and property against lightning is to provide a means by which a lightning discharge can enter or leave the earth without resulting in damage, loss of man hours, property or life. Grounding and lightning protection systems (LPS) require periodic inspection, testing and maintenance to retain their effectiveness throughout the life of the facility. Reference (a) as supplemented by the requirements of reference (b) provide the minimum acceptable requisites for the protection of all explosives areas used for the

following: developing, manufacturing, testing, handling, storing, maintaining and demilitarizing or disposing of ammunition and explosives from the effects of direct and indirect lightning strikes. MCAGCC shall adhere to these requirements.

(2) Concept of Operations

a. References (a) through (i) contain guidance and mandatory requirements to provide LPS testing procedures and visual inspection.

b. Lightning protection *is* required for all explosives areas (Per reference (a), exceptions for employing LPS will be reviewed on a case-by-case basis).

c. The following requirements shall be met to provide minimum protection for explosives areas against lightning strikes:

(1) A path must be established that connects the LPS to earth with such a low impedance that the discharge follows it in preference to any other.

(2) A low resistance connection must be made with the earth electrode subsystem.

(3) A low impedance interface must be established between the earth electrode subsystem and earth.

d. Appendix A through F provide guidance for equipment configuration, testing and reporting.

5. Command and Signal

a. Command. This SOP is applicable to all ordnance handlers, supervisors, officers and civilian personnel from commands and organizations that perform or supervise explosive operations and provide maintenance of ammunition facilities aboard the Combat Center.

TABLE OF CONTENTS

<u>IDENTIFICATION</u>	<u>TITLE</u>	<u>PAGE</u>
Chapter 1	RESPONSIBILITIES.....	1-1
1.	General.....	1-1
2.	Facilities Management Division.....	1-1
3.	Engineering Branch.....	1-2
4.	Center Safety.....	1-2
5.	Units or Tennant Commands.....	1-2
6.	Training.....	1-3
Chapter 2	GENERAL.....	2-1
1.	General.....	2-1
2.	Safety Guidelines.....	2-1
3.	Lightning Strike Report.....	2-2
Chapter 3	THREE POINT FALL OF POTENTIAL RESISTANCE TO EARTH TEST.....	3-1
1.	General.....	3-1
2.	Resistance to Earth Inspection Cycle.....	3-1
3.	Referencing Electrode Location.....	3-1
4.	Equipment.....	3-1
5.	Procedures.....	3-1
Chapter 4	GENERAL.....	4-1
1.	General.....	4-1
2.	Bonding Test Inspection Cycle.....	4-1
3.	Equipment.....	4-1
4.	Procedures.....	4-1
Chapter 5	TESTING AND IDENTIFICATION OF AIRCRAFT GROUNDING POINTS.....	5-1
1.	General.....	5-1
2.	Resistance to Earth Test Inspection Cycle.....	5-1
3.	Equipment.....	5-1
4.	Procedures.....	5-1
Chapter 6	VISUAL INSPECTION OF GROUNDING SYSTEMS FOR EXPLOSIVES AREAS.....	6-1
1.	General.....	6-1
2.	Visual Inspection Cycle for LPS.....	6-1
3.	Inspection Team Membership.....	6-1
4.	Procedures for Visual Inspection LPS.....	6-1
5.	Procedures for Visual Inspection of Aircraft Grounding Points.....	6-3

CHAPTER 1

Responsibilities

1. General. This chapter identifies those commands, units and/or personnel responsible for performing the various duties required for resistance-to-earth testing and visual inspection of MCAGCC's explosives areas and lists specific actions for which they are responsible. These procedures may be utilized at other explosives areas when evaluated on a case-by-case basis.

2. Facilities Management Division

a. Provide maintenance for all MCAGCC explosives areas and tenant commands

b. Have the responsibility for ensuring all explosives areas with lightning, electrical and electrostatic grounding systems are inspected, maintained, repaired and tested in accordance with reference (a) and other applicable codes and safety guidelines.

c. Inform, via E-Mail, Center Safety, Center Magazine Area (CMA), Marksmanship Training Unit (MTU) and other tenant commands prior to beginning the "Test-Inspection-Repair" cycle.

d. Forward to Center Safety all completed "Test-Inspection-Repair" results and test data for distribution to each unit/tenant command requiring lightning protection and grounding system (LPS) "Test-Inspection-Repair".

e. Per references (g), (h) and (i), conduct (with two formally trained personnel) visual inspection, and electrical continuity/grounding tests for all primary girdles, ordnance grounds, static grounds, power grounds, instrumentation grounds, structural grounds, conductive floors, metal masses, conductive mats, electrical equipment, machinery and all other devices that are part of the LPS and to repair LPS of explosives areas.

f. Ensure all minor discrepancies found during testing are corrected immediately. If it is determined the repair work required will need more resources than are available (*i.e.*, broken grounding cables), appropriate action to correct the deficiency shall be implemented within five working days.

g. During visual LPS inspection:

(1) Provide a visual LPS inspection team leader.

(2) Per references (g), (h) and (i), document the visual inspection.

(3) Coordinate the LPS inspection schedule with explosives area's supervisor who will be inspected.

(4) Obtain from Center Safety a data package of the explosives area to include:

(a) A grounds test plan indicated in the references (g), (h) and (i).

(b) A copy of the most recent electrical test data for the facility.

3. Engineering Branch

a. Maintain as built drawings for all explosives buildings, magazines, new additions and replacement equipment including grounding and LPS. Forward all LPS drawings of explosives facilities requiring construction or modification for the Explosive Safety Officer's (ESO) review. Provide drafting support for drawings of grounding systems for the Grounding System Test Plan (GSTP) as requested by the ESO.

b. Ensure all modification or new construction drawings for explosives areas are forwarded to the ESO for review. All designs to explosives areas require written approval of the ESO.

c. Assure no excavation permit *is* issued in the vicinity of explosives areas (*i.e.*, buildings and/or magazines) without a thorough review to prevent the disturbance of any existing grounding and LPS. Such excavation permits must be signed by the Digging Permit Coordinator.

4. Center Safety

a. Provide oversight for the LPS visual inspection, resistance-to-earth testing grounding and bonding repairs.

b. Maintain a GSTP for the visual and electrical testing of primary and secondary ground systems components. Once promulgated, deviations from the approved GSTP are not allowed without approval of the ESO.

c. Maintain permanent records for "Test-Inspection-Repair" actions and test data for the lifetime of each explosives facility.

d. Review all test data reports to identify those facilities, which exceed required electrical ground tests maximum resistance values.

e. Issue shutdown notices to the cognizant unit/tenant command responsible for the facility if the LPS deficiency has not been abated within 30 days.

f. Review the deficiency abatement file with the Maintenance Branch, Facilities Maintenance Division to ensure repairs are being made.

5. Units or Tennant Commands. Prior to commencing of LPS "Test-Inspection" procedures detailed in this Manual, the Officer-in Charge, Department Head or Commanding Officer shall:

a. Brief the LPS test team on any explosive hazards that may exist in the explosives area at the time when testing will occur.

b. Provide a minimum of two qualified/certified personnel, if necessary, to handle explosives.

c. Coordinate with Center Safety, personnel who are qualified /certified in LPS "Test-Inspection" procedures to provide on-site verification for the LPS "Test-Inspection-Repair" of the explosives area.

d. In addition to the aforementioned responsibilities, during visual LPS inspection the Officer-in-Charge, Department Head, Commanding Officer shall:

(1) Provide personnel to the visual LPS inspection team. At least one person shall have completed formal training in the methodology of visual LPS inspection procedures contained in references (a) and (b).

(2) Ensure the explosives area is available for the inspection team.

(3) Ensure the explosives area is free of any exposed explosives, explosive dust or exposed electro-explosive devices (EEDs) (Down loading of any magazine is not required).

(4) Briefing the visual inspection team on any construction or modifications made to the facility since the last visual inspection.

6. Training. On the Job Training (OJT) can be implemented so that a sufficient number of personnel (as determined by the Officer-in-Charge, Department Head or Commanding Officer) can be shown the procedures required to perform the LPS "Test-Inspection" contained in this Manual. It shall be given by those personnel who have been formally trained in the proper techniques for the LPS "Test-Inspection" procedures.

Chapter 2

General

1. General. There are several hazards to personnel safety when completing the LPS "Inspection-Test" procedures indicated in this Manual. The following general safety requirements discussed in this chapter are a generic supplement to other safety requirements specified in each respective unit's or tenant command's standard operating procedures.

2. Safety Guidelines

a. In the event any unusual, abnormal or unsuspected condition is encountered, the operation will be halted and the immediate supervisor will be notified. The immediate supervisor will evaluate the condition and will consult the next level of authority to determine corrective action necessary.

b. Personnel and explosive limits must not be exceeded at any time. Transient personnel must comply with the same safety requirements as operating personnel upon entering the work site.

c. No electrical testing or visual inspections shall be performed in the event of an electrical storm or storm warning.

d. Test equipment specifically designed for the direct reading of resistance-to-earth testing must meet standards per reference (a).

e. Silk, wool, rayon, nylon, or other synthetic-fiber outer or undergarments shall not be worn while conducting LPS "Test-Inspection" procedures.

f. All ground test wiring will be visually checked for breaks and for poor or loose connections prior to starting any LPS resistance-to-earth tests and/or LPS bonding tests.

g. When testing earth-covered magazines personnel shall walk up at an angle and if necessary, operating personnel will use approved safety equipment (i.e., rope and harness).

h. Regardless of which instrumentation is used, ensure no explosives are bonded to the grounding system at the time of the resistance-to-earth test.

i. Appropriate eye protection and gloves will be used when driving grounding test electrodes for the LPS resistance-to-earth testing.

j. When accomplishing LPS "Inspection-Test" procedures in and around an ammunition storage area, personnel shall be wearing safety shoes nonconductive and cotton coveralls.

k. The Biddle Det 2/2 Ground Tester, catalog number 250202, may develop up to 50 volts or 50 milliamps across different pairs of output terminals. To avoid electrical shock, treat this output as dangerous.

3. Lightning Strike Report. Any indication of damage produced by a lightning strike to an explosives area or its lightning protection system shall immediately be reported to NSWX/IHD (Code 044). The lightning strike report (Appendix A) shall be submitted immediately to Center Safety. Photographic records of damage suspected to have resulted from a lightning strike shall be obtained prior to repair.

Chapter 3

Three-Point Fall-of-Potential Resistance-to-Earth Test

1. General. The three-point fall-of-potential test method is the accepted method in measuring the resistance-to-earth of grounding systems for Naval/Marine Corps explosives areas. It involves injecting a known value of low frequency alternating current between a "current" reference electrode and the "grounding system under test". A second reference electrode, the "potential" electrode, is located between the "current" electrode and the "grounding systems under test."

2. Resistance-to-Earth Inspection Cycle. Measurements for the resistance-to-earth test shall be completed:

a. Every month for the first year for new primary or secondary grounding girdles.

b. Monthly for the first year, when an existing ground system is modified or added to which disturbs more than half of the total ground system.

c. Every two years after the first year (within 30 days past the date of the inspection, weather permitting.)

3. Referencing Electrode Location. To obtain the most accurate data a fall-of-potential "S-Curve" ground test of each explosives area should be conducted once during the life time of the facility. For new construction of an explosive area this test shall be completed prior to the monthly resistance-to-earth test.

When necessary, completion of this test will be beneficial in obtaining the best reference points to conduct a resistance-to-earth test for an explosive area.

4. Equipment. The following is required to conduct this test:

a. As shown in enclosure (2), a Biddle Det 2/2 ground Tester, catalog number 250202 or equivalent.

b. A minimum of two reference electrodes of 1/2 inch diameter and minimum of 18 inches long of copper or steel (galvanized or stainless).

c. Three insulated test lead wires of sufficient length, that meet the requirements of the test procedures (indicated in this chapter, paragraph five) are required for the performance of the testing detailed in this procedure. Ensure the test leads are marked "E", "C" and "P."

5. Procedures

a. Prior to administering the fall-of-potential test, the test operator will perform the following pre-operational checks of the equipment:

b. Ensure that the Biddle Det 2/2 Ground Tester, catalog number 250202, or equivalent is properly calibrated per reference (f) and the appropriate tag indicates the date of next calibration.

c. Perform battery test to check the serviceability of the batteries and recharge the tester, if necessary.

d. Ensure that electrodes meeting the specifications detailed in paragraph three of this chapter are available.

(1) Place the C2 electrode as far from the grounding test-well under test as practical (minimum of 100 feet (30.5mm)). Drive the electrode to a minimum depth of eight inches. The grounding test-wells for each building number are indicated in references (g) and (h).

(2) Place the P2 electrode into the ground at a minimum distance of 62 feet (18.9m) from the grounding test point being tested and in line with the C2 electrode.

(3) Place the tester at the grounding test-well, as determined by the ground test plan, for the respective building number.

(4) Connect the "E" terminal lead wire from the tester (minimum of two feet in length) to the respective ground test-well with an "alligator" clip.

(5) Connect the "current" test lead wire marked "C" to the C2 terminal. Stretch the wire out in a straight line. The "current" test lead wire is the longer of the two lead wires.

(6) Connect the "potential" test lead wire marked "P" to the P2 terminal. Stretch the wire out in straight line. The "potential" test lead wire is the shorter of the two lead wires.

(7) Attach the "C" test lead wire to the C2 electrode as illustrated in appendix B.

(8) Attach the "P" test lead wire to the P2 electrode as illustrated in appendix B.

(9) Test Operator One shall signal that a resistance measurement is to take place by speaking loudly "Test" to Test Operator Two.

(10) For the Biddle Det 2/2 Ground Tester, catalog number 250202, or equivalent press on/off switch and hold or rotate in the lock position. Test Operator One shall record reading on the respective ground test-well for the building number being tested. The test should read 25 ohms or less.

(11) If there are any discrepancies, Center Safety and the Commanding Officer of the explosive area should be notified by the most expedient method. If it is determined that an excessive reading is indicated, improve the earth contact of the C2 electrode by driving it deeper, relocating or using a longer electrode. If the test fails see paragraph three of this chapter and follow procedures per reference (a).

(12) After completion of the test, sufficiently mark the points where the C2 and P2 probes are placed. For each successive test each probe will be placed at those marked areas.

(13) Disconnect test leads, remove earth electrodes to start bonding test procedures indicated in chapter four of this Manual. If the building has more than one ground test well, repeat fall-of-potential procedures (paragraphs 3(b) through 3(k)) until testing of all ground test-wells are completed.

(15) In reporting the test data, all inspection sheets will be compiled into one packet and forwarded to the ESO for review.

Chapter 4

General

1. General. Bonding resistance testing is the most important quality control technique that can be used to quantify the effectiveness of the explosives area's LPS. The bonding resistance test method is a simple point-to-point resistance measurement. This chapter provides specific test procedures to be applied in the performance of bonding resistance testing.

2. Bonding Test Inspection Cycle. Per reference (a), point-to-point bonding resistance test shall be conducted every 24 months. (The point-to-point bonding test should be coordinated with the earth resistance testing specified in chapter three of this order.

3. Equipment

a. A Biddle Det 2/2 Ground Tester, catalog number 250202, or equivalent shall be utilized to conduct the point-to-point bonding resistance testing. The test shall be configured as shown in enclosure (3).

b. Two jumper wires shall be utilized for the test. Two insulated test lead wires of sufficient length that meet the requirements of the test procedures indicated in this chapter, are required for the performance of the testing detailed in the following procedures. Ensure one of the test leads is marked with an "E." The other can be unmarked for this procedure.

c. A file shall be used to prepare each test point. If a file cannot be acquired, "alligator" clips which can "bite" into the item under test shall be utilized as an alternate piece of equipment for this procedure.

4. Procedures. WARNING: Prior to conducting the point-to-point bonding test to a facility, ensure no ordnance items are connected to the grounding system.

a. Prior to administering the point-to-point resistance test, the test operator shall perform the following pre-operational checks of the equipment:

b. Per reference (f), ensure that the Biddle Det 2/2 Ground Tester, catalog number 250202, or equivalent is properly calibrated and the appropriate tag indicates the date of next calibration.

c. Perform battery test to check the serviceability of the batteries and recharge the tester, if necessary.

d. Measure the resistance of the lead wires as illustrated in appendix

(1) Connect a jumper wire to terminal C2 and P2.

(2) Connect a jumper wire to terminal C1 and P1.

(3) Connect the "E" lead wire, the shortest lead, to the jumpered C2 and P2 terminal.

(4) Connect the bonding lead wire, the longest lead, to the jumpered C1 and P1 terminal.

(5) Tighten all terminals.

(6) Connect the free ends of the lead wires "E" and the bonding lead wire together.

(7) Measure the resistance of the lead wires and record. To obtain accurate results, subtract the lead resistance from all subsequent readings obtained during the test. Annotate measured lead resistance on the inspection sheet.

(8) Disconnect the free ends of the test lead wires.

(a) Connect the "E" lead wire (minimum of 2 feet in length) to a respective ground test point, with an "alligator" clip, that has completed the resistance-to-earth test per chapter three of this order.

(b) Per reference (g), (h) and (i) place the bonding lead wire to each point under test as indicated on the explosives building's ground test plan.

e. The bonding lead wire shall be sufficient length to accomplish all point-to-point bonding tests from one location of the respective explosives building.

f. Either file off any rust or paint to the respective bonding point or apply an "alligator" clip to the "bite" at the respective bonding point to obtain an accurate reading.

g. Test Operator Two will indicate the bonding point is prepared for testing by speaking loudly "Test" to Test Operator One.

h. When manning the Biddle Det 2/2 Ground Tester, catalog number 250202, or equivalent Operator One will press the on/off switch and hold or rotate in the lock position. Record the reading of the bonding test point on the explosives building's test data sheet. The test should read one ohm or less.

i. Test Operator One will indicate to Test Operator Two that the bonding test point is completed by speaking loudly "Test Completed" or "Next." If there are any discrepancies, Center Safety and the Commanding Officer of the explosives area being provided the test will be notified by the most expedient method.

j. Repeat procedures listed in paragraph 4(b) through 4(f) of this chapter, until all bonding test points have been tested as indicated on the respective explosives building's ground test plan.

k. After testing disconnect all test lead wires and ensure all tools and equipment are removed from the work area.

l. All inspection data sheets will be compiled into one packet and forwarded to Center Safety for review.

Chapter 5

Testing and Identification of Aircraft Grounding Points

1. General. Static electricity is generated by a separation of unlike bodies. A primary manifestation of static electricity is the discharge or sparking of accumulated charges. Electrostatic charges, positive and negative, always occur in pairs. They become evident when these pairs, having been in contact with each other, are separated. For significant potential to be developed the bodies holding the charges must become and remain insulated from each other. Catastrophic results can occur from a discharge of static electricity into a squib, cartridge or Electro-Explosive Device (EED). Care for ensuring aircraft, weapon system, fueling system and personnel are kept at ground potential will minimize the dangerous effects of static electricity. References (d) and (e) list procedures for the resistance-to-earth test for all military aircraft static grounds on board MCAGCC's Expeditionary Airfield (EAF).

2. Resistance-to-Earth Test Inspection Cycle

a. Aircraft static grounding points on board the EAF shall be performed periodically in Manual to determine if there has been any degradation of the grounding system.

b. These grounding test points shall be provided resistance-to-earth testing every 12 months. This will ensure that there has been no degradation to the grounding system from maintenance activities on the EAF's matting.

3. Equipment

a. A Biddle Det 2/2 Ground tester, catalog number 250202, or equivalent shall be configured as shown in enclosure (5).

b. Two reference electrodes of 1/2 inch diameter and a minimum of 18 inches long of cooper or steel {galvanized or stainless}.

c. Three insulated test lead wires of sufficient length, that meet the requirements of the test procedures indicated in this chapter. Ensure the test leads are marked "E", "C" and "P."

4. Procedures. The below procedures shall be followed when performing the fall-of-potential resistance-to-earth test.

a. Prior to administering the test, the operator will perform the following pre-operational checks of the equipment:

b. Per reference (f) ensure the Biddle Det 2/2 Ground Tester, catalog number 250202, or equivalent is properly calibrated and the appropriate tag indicates the date of next inspection.

c. Perform battery test to check the serviceability of the batteries and recharge the tester, if necessary.

d. Ensure that electrodes meeting specifications detailed in the following procedures are available.

(1) Place the C2 electrode into the ground at a distance of 100 feet (30.5m) from the grounding test point being evaluated.

(2) Place the tester at the grounding test point, as determined by the grounding test plan (see reference (i)).

(3) Connect the "E" terminal lead wire from the tester (minimum of two feet in length) to the respective ground test point with an "alligator" clip.

(4) Connect the "current" test lead wire marked "C" to the C2 terminal. Stretch the wire out in a straight line. The "current" test lead wire is the longest of the two test lead wires.

(5) Place the P2 electrode into the ground at a distance of 62 feet (18.9m) from the grounding test point being evaluated and in line with the C2 electrode. If the aircraft grounding test points cannot be reached using the 100 feet ("C" lead) and 62 feet ("P" lead), increase the lead lengths proportionately using the 62 percent rule. For example, if the "C" lead is over 200 feet the "P" lead is 124 feet.

(6) Connect the "potential" test lead wire marked "P" to the P2 terminal. Stretch the wire out in a straight line. The "potential" test lead wire is the shortest of the two test lead wires.

(7) Attach the "C" test lead wire to the C2 electrode as illustrated in appendix E.

(8) Attach the "P" test lead wire to the P2 electrode as illustrated in appendix E.

(9) Test Operator One shall signal that a resistance measurement is to take place by speaking loudly "Test" to Test Operator Two.

(10) Using the Biddle Det 2/2 Earth Tester, catalog number 250202, or equivalent press the on/off switch to the lock position.

(11) Test Operator One shall record the reading on the respective grounding test point. The test should read 10,000 ohms or less. When measuring fueling operation's grounding points it should read 10 ohms.

(12) If there are any discrepancies, Center Safety and the Ordnance Officer of the EAF provided the test will be notified immediately. If it is determined that an excessive reading is indicated improve the earth contact of the C2 electrode by driving it deeper, relocating or using a longer electrode.

(13) To appropriately identify grounding points that have passed resistance-to-earth testing, mark grounding points per appendix F.

(14) Prepare all equipment for movement to the next grounding test point by disconnecting test leads, remove earth electrodes, pick up tools, etc. Per reference (i), repeat fall-of-potential procedures (paragraph 4(b) through paragraph 4(1)) until testing of all grounding test points are completed.

(15) In reporting the test data all inspection data sheets will be compiled into one packet and forwarded to Center Safety for review.

Chapter 6

Visual Inspection of Grounding Systems for Explosives Areas

1. General. While it is not possible to confirm that a facility is in complete compliance with a visual inspection, it is possible to detect some of the obvious deficiencies.

- a. Broken or missing bonding straps.
- b. Frayed bonding jumpers.
- c. Broken or disconnected bonding.
- d. Broken or disconnected lightning protection conductors.
- e. Other items to ensure protection from electrostatic discharge.

2. Visual Inspection Cycle for LPS. LPS for each explosives area on board MCAGCC shall be visually inspected every six months for evidence of corrosion and ensure that no physical damage has been done to the system.

3. Inspection Team Membership. To ensure that each explosives area's LPS meets the requirements of references (a), (b) and (e), LPS visual inspection teams shall consist of at least two personnel that have received formal training in LPS inspections procedures.

4. Procedures for Visual Inspection LPS

a. References (g), (h) and (i) provide checklists to be used during LPS visual inspections and shall be implemented when the inspection team conducts their operation.

b. During the checking of bonding connections both visual and physical (where practical), inspections shall be conducted.

c. During their inspection the LPS visual inspection team will:

(1) Inspect the inside and outside of each explosives building.

(2) Ensure cables connected to lightning masts are:

(a) In good condition and are at least AWG #1/0 or larger bare copper wire.

(b) Attached to the masts and have no sharp bends present in the wire.

(3) Ground grab bars are not painted and are installed outside of areas where hazards exist.

(4) All metal masses (400 square inches or larger) are connected to the secondary ground girdle. Examples of masses are: radiators, conduits, tanks, downspouts, gutters, stationary machinery, stair rails, columns, beams, siding, trusses, etc.

(4) Ordnance static and instrumentation ground busses connections are secure and grounds are clearly identified. Connection points are to be free from paint, corrosion and foreign material that may degrade the efficiency of the system.

(5) If the following items are part of the grounding system: conductive chairs, carts, work benches etc., are identified and clearly labeled as conductive and their inspection dates are indicated.

(6) Portable ground cables, installed ground cables, and ground reels are free of defects and are in good operating condition.

(7) 120 volt single phase receptacles installed outdoors or in wet locations are ground fault circuit interrupter equipped.

(8) Exterior overhead pipe lines entering a lightning protected structure are bonded to the secondary ground girdle. If pipes come within side-flash distance of the structure or LPS they shall be bonded to the secondary grounding system.

(9) Lightning surge arrestors or surge suppressors on all power, communications, data and process control conductors that are installed in explosives buildings and have not been degraded to the point they are no longer effective.

(10) All utility lines and metallic conductors including intrusion detection lines, water, electrical, steam, air-conditioning lines, etc., are buried underground within 50 feet of the facility.

(11) The electrical service to an explosive facility is arranged so that it cannot be energized by switches located at one or more control points outside, but immediately adjacent to the explosive work area.

(12) Per reference (b), fences are bonded to the LPS if they come within side-flash distance.

(a) Fences must be grounded if power lines cross the fence line directly overhead or run parallel to the fence line.

(b) Fences are to be grounded in places where personnel routinely contact the fence and areas where structures or materials are located within six feet. No ground loops are present in the facility.

(c) Verify:

1. There are no trees in the protected area on lightning protected buildings.

2. Grounding system connections are secure and free of paint, corrosion and foreign materials that may impair ground system efficiency. Metal masses shall be connected at their lowest point to the secondary girdle.

(d) Review previous test records to ensure fences are bonded from gatepost to gatepost, gatepost to gate and gatepost to secondary grounding girdle, if within the zone of protection. If outside the zone of protection, ensure ground rods are on each side of the gate.

(e) Compile the checklist for the LPS visual inspection into one packet and forwarded to Center Safety for review and retention.

5. Procedures for Visual Inspection of Aircraft Grounding Points.

a. Aircraft grounding points shall have their LPS visually inspected every six months.

b. Reference (i) provides a checklist to be used during LPS visual inspections and shall be implemented when the inspection team conducts their inspection.

c. During the checking of bonding connections, both visual and physical (where practical) inspections shall be conducted.

d. The LPS visual inspection team shall ensure:

(1) Aircraft grounding points are appropriately identified per appendix F.

(2) Grounding points have connections which are free and secure from paint, corrosion or foreign materials which might impair the efficiency of the system.

5. Compile the checklist for the visual inspection into one packet and forward to Center Safety for review and retention. If there are any discrepancies, the inspection team leader will notify Center Safety and the Ordnance Officer for the EAF.

APPENDIX A

LIGHTNING STRIKE REPORT

NO. _____

BUILDING# _____ ORIG _____ TIME _____

REPORTED BY _____ REPORTED TO _____

NOTIFICATION

OFFICER OF THE DAY DATE _____ TIME _____

COMMAND DUTY OFFICER DATE _____ TIME _____

WEAPONS OFFICER DATE _____ TIME _____

EXPLOSIVES SAFETY OFFICER DATE _____ TIME _____

INVESTIGATION

WEAPONS OFFICER DATE _____ TIME _____

EXPLOSIVE SAFETY OFFICER DATE _____ TIME _____

PHOTOGRAPHS TAKEN _____ YES _____ NO _____

FINDINGS _____

RECOMMENDATION

_____ NO DAMAGE. NO ACTION REQUIRED.

_____ SEE ATTACHED GROUNDING DISCREPANCY NOTICE (GDN)

_____ NOTIFIED NSCW/II-JD (CODE 044)

AUTHORIZATION TO PROCEED WITH OPERATIONS

COMMANDING OFFICER _____

SAFETY OFFICER _____

WEAPONS OFFICER _____

CORRECTIVE ACTION VERIFIED BY SAFETY OFFICE

DATE _____ NAME _____

APPENDIX B

RESISTANCE-TO-EARTH TESTER CONFIGURATION FOR BIDDLE DET 2/2 GROUND TESTER

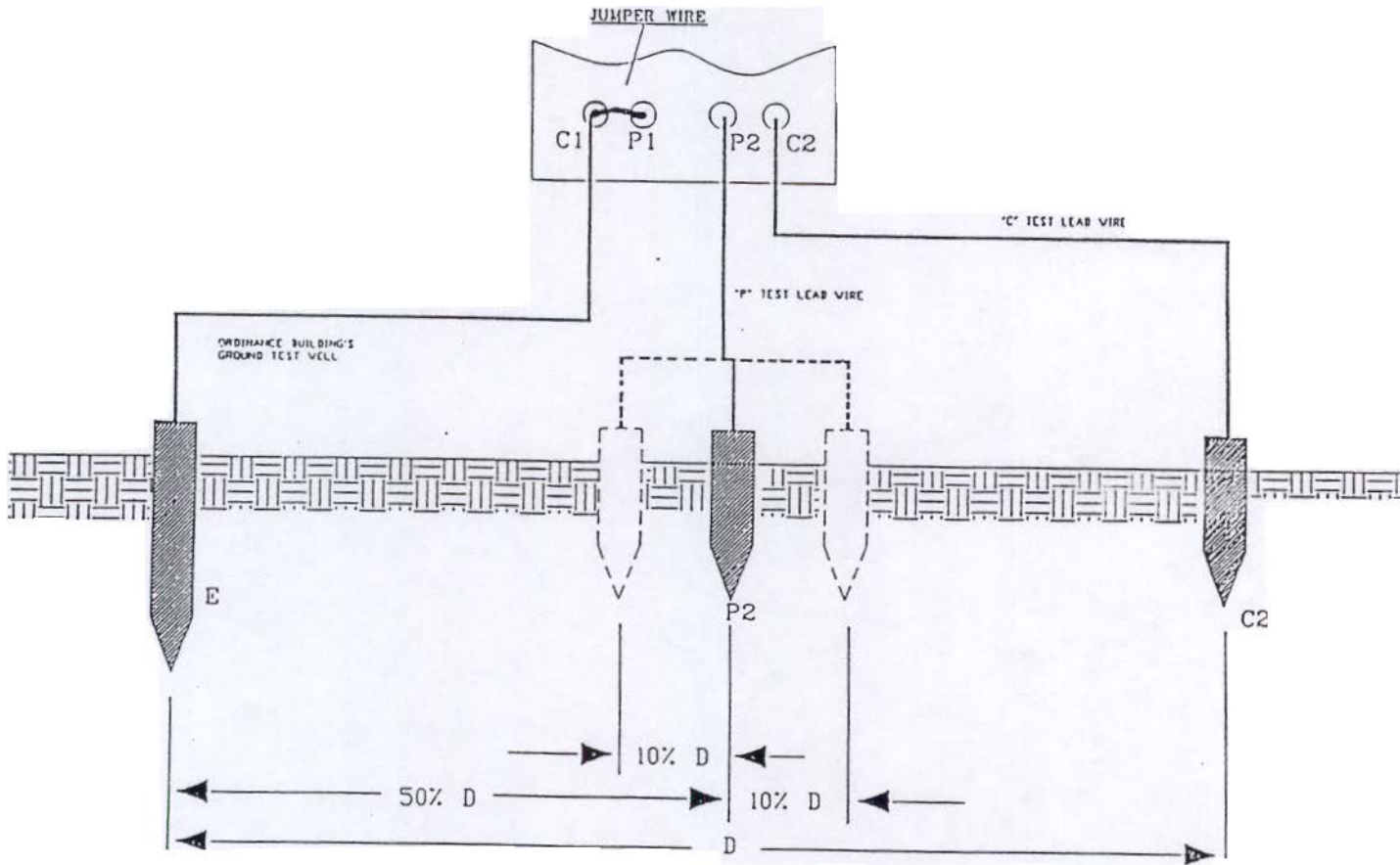

APPENDIX C

RESISTANCE-TO-EARTH TESTER CONFIGURATION TEST FOR RESISTANCE OF TEST LEAD WIRES

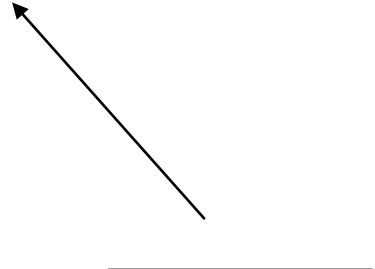
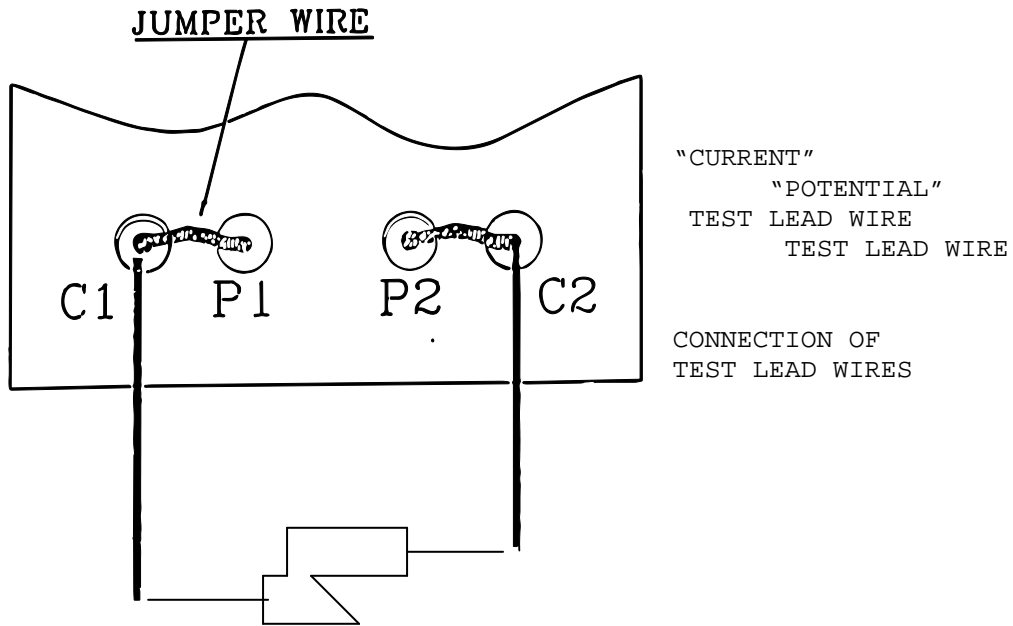

APPENDIX D

BONDING RESISTANCE TESTING EQUIPMENT CONFIGURATION

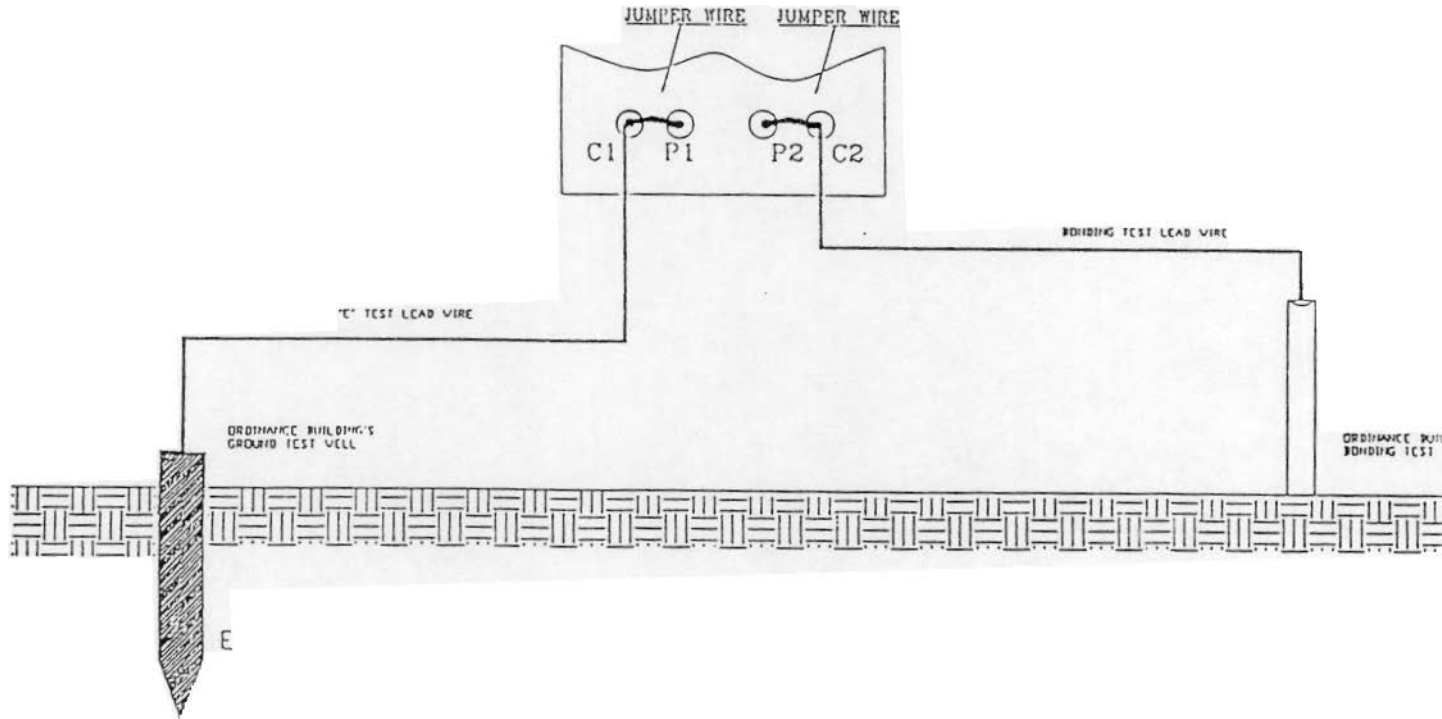

APPENDIX E

RESISTANCE-TO EARTH CONFIGURATION FOR BIDDLE DET 2/2 GROUND TESTER FOR MILITARY AIRCRAFT

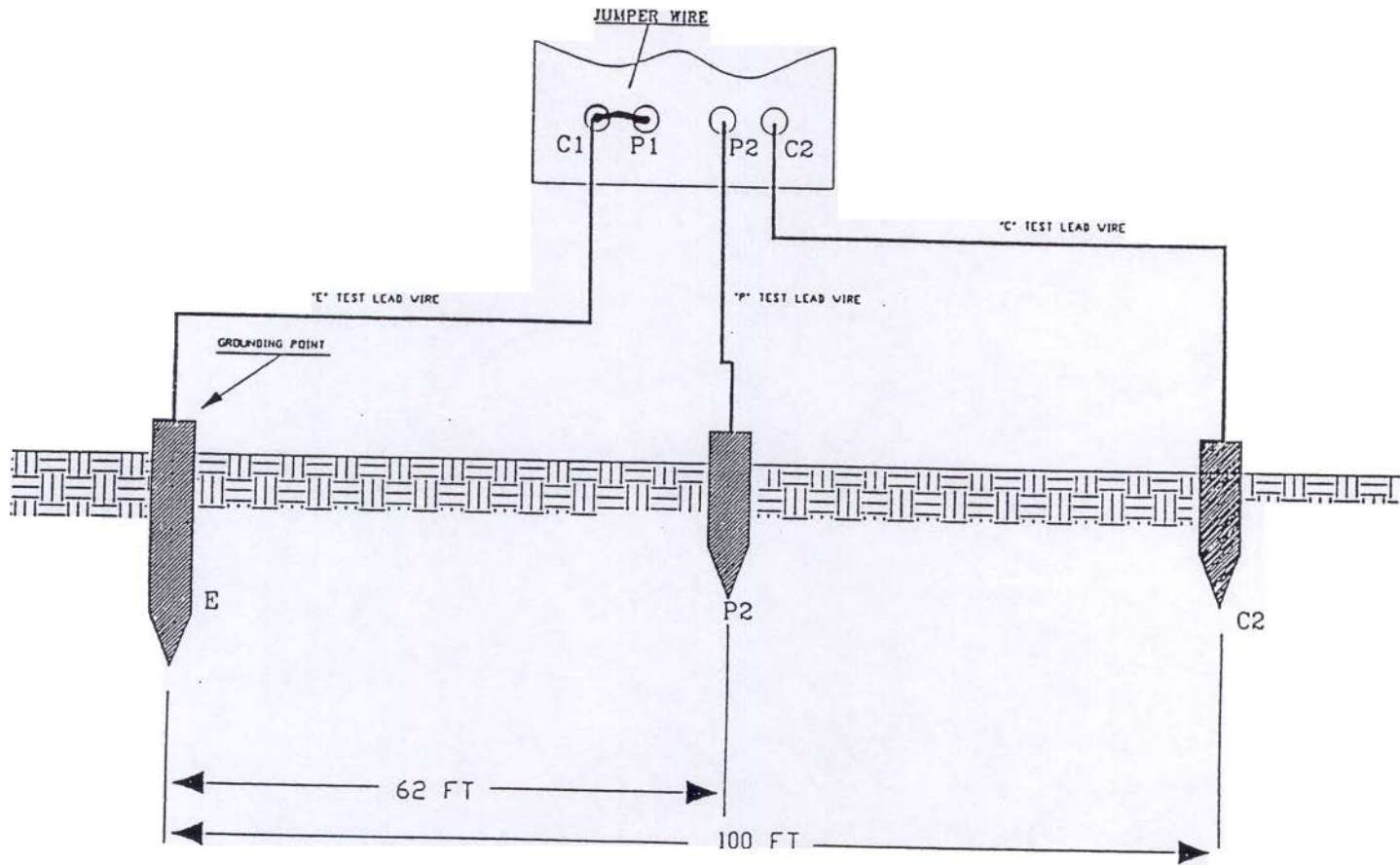

APPENDIX F

AIRCRAFT GROUND POINT IDENTIFICATION

NOTES:

1. ALL LETTERS SHALL BE 1" HIGH.
2. TESTING INFORMATION SHALL BE CENTERED AS SHOWN WITH 3/4" SPACING BETWEEN L

GROUNDING BOX

TT-P-85 REFLECTORIZED YELLOW/REFLECTORIZED BEADS, TT-B1325A TYPE III (SEE SPECIFICATIONS)

TT-P-II06 BLACK PAINT

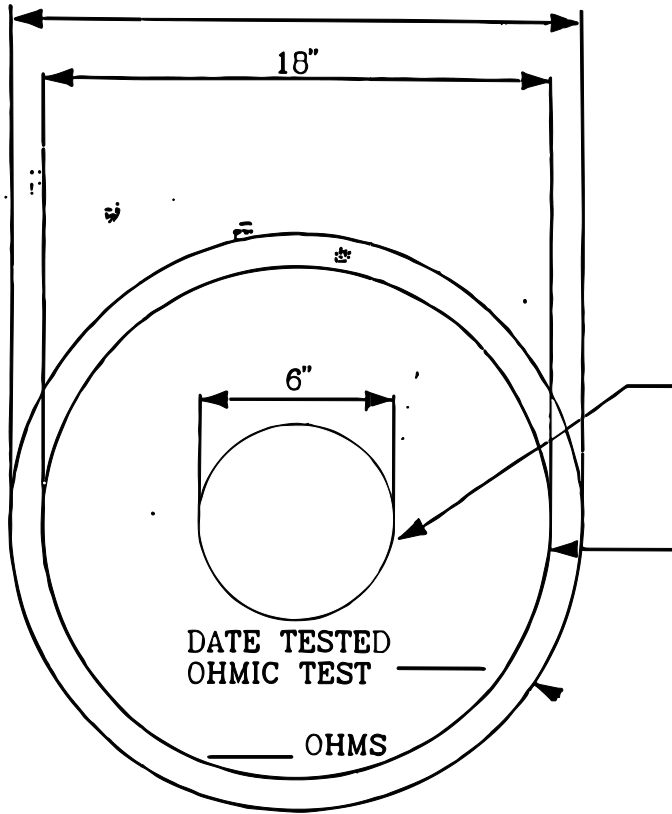

GROUND CONNECTION